



International Journal of Multidisciplinary Research in Science, Engineering and Technology

(A Monthly, Peer Reviewed, Refereed, Scholarly Indexed, Open Access Journal)



Impact Factor: 8.206

Volume 9, Issue 4, April 2026

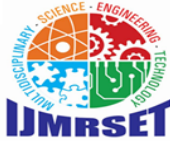

Solar Powered IoT-Based Smart Home Automation and Monitoring System

Prof. Sagar Rahangdale¹, Nikhita T. Kapse², Ritesh V. Sable³, Ritesh V. Ghavghave⁴, Mohit A. Mendhe⁵,
Abhishek U. Dole⁶, Bramhanand A. Bhure⁷

Asst. Professor, Dept. of Electrical Engineering, Wainganga College of Engineering and Management, Nagpur,
Maharashtra, India¹

UG Student (B. Tech Student), Dept. of Electrical Engineering, Wainganga College of Engineering and Management,
Nagpur, Maharashtra, India^{2,3,4,5,6,7}

ABSTRACT: The proposed solar-powered IoT-based smart monitoring and control system leverages renewable energy to enable efficient and sustainable operation across diverse applications. A photovoltaic panel generates electricity, which is stored in a rechargeable battery and regulated through a charge controller and buck converter to ensure stable power delivery. An ESP32 microcontroller serves as the core processing unit, interfacing with sensors that measure temperature, humidity, gas concentration, motion, and voltage.

The collected data is transmitted via Wi-Fi to the Blynk mobile application, allowing users to remotely monitor environmental conditions and control appliances such as lights and fans. This integration of renewable energy with IoT technology provides a cost-effective, energy-efficient, and scalable solution suitable for smart homes, agricultural monitoring, and industrial automation. The system demonstrates how sustainable energy harvesting combined with intelligent control can contribute to reducing energy costs, enhancing reliability, and promoting eco-friendly practices in modern smart environments.

KEYWORDS: Solar energy; IoT; ESP32 microcontroller; Smart monitoring; Renewable energy; Charge controller; Buck converter; Blynk application; Remote control; Smart homes; Agriculture; Industrial automation; Energy efficiency; Sustainability.

I. INTRODUCTION

The rapid advancement of the Internet of Things (IoT) has transformed conventional monitoring and control systems into intelligent, interconnected platforms capable of enhancing efficiency, sustainability, and user convenience. At the same time, the increasing global demand for renewable energy solutions has positioned solar power as a viable and eco-friendly alternative to conventional energy sources. Integrating IoT with solar energy systems enables the development of smart infrastructures that are not only energy-efficient but also environmentally sustainable.

In this work, a solar-powered IoT-based smart monitoring and control system is proposed to address the dual challenges of energy consumption and intelligent automation. The system harnesses solar energy through a photovoltaic panel, with energy stored in a rechargeable battery and regulated using a charge controller and buck converter to ensure stable operation. An ESP32 microcontroller acts as the central processing unit, interfacing with multiple sensors to measure parameters such as temperature, humidity, gas concentration, motion, and voltage. The collected data is transmitted via Wi-Fi to the Blynk mobile application, enabling real-time monitoring and remote control of appliances including lights and fans.

The proposed system is designed to be cost-effective, scalable, and adaptable to diverse applications such as smart homes, precision agriculture, and industrial automation. By combining renewable energy harvesting with IoT-based control, the system contributes to reducing energy costs, improving reliability, and promoting sustainable practices. This research highlights the potential of integrating solar energy with IoT technologies to create intelligent, eco-friendly solutions for modern smart environments.

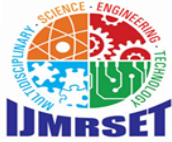

International Journal of Multidisciplinary Research in Science, Engineering and Technology (IJMRSET)

(A Monthly, Peer Reviewed, Refereed, Scholarly Indexed, Open Access Journal)

II. AIM AND OBJECTIVES

Aim:

The primary aim of this project is to design and implement a *solar-powered iot-based smart monitoring and control system* that integrates renewable energy with intelligent automation to achieve efficient, sustainable, and cost-effective operation across smart homes, agriculture, and industrial environments.

Objectives

- **To harness** solar energy using a photovoltaic panel and store it in a rechargeable battery for sustainable power supply.
- **To regulate** energy flow through a charge controller and buck converter, ensuring stable voltage and efficient utilization.
- **To develop** an IoT-enabled framework using the ESP32 microcontroller for real-time data acquisition and processing.
- **To integrate** multiple sensors (temperature, humidity, gas, motion, voltage) for comprehensive environmental monitoring.
- **To transmit** sensor data via Wi-Fi to the Blynk mobile application, enabling remote monitoring and control.
- **To implement** smart appliance control (lights, fans) through mobile-based commands for enhanced user convenience.
- **To evaluate** the system's performance in terms of energy efficiency, cost-effectiveness, and scalability for diverse applications.
- **To promote** sustainable practices by combining renewable energy harvesting with IoT-based automation.

III. PROPOSED ARCHITECTURE

The architecture integrates renewable energy generation with IoT-based automation for efficient and sustainable operation. The system begins with a solar panel that converts sunlight into unregulated DC power. This power is stabilized by a charge controller and stored in a 12V battery, ensuring continuous operation even under low-light conditions. A buck converter (LM2596) steps down the voltage to 5V DC, supplying regulated power to the ESP32 microcontroller and peripheral sensors.

The ESP32 microcontroller serves as the central processing unit, interfacing with multiple sensors:

- **DHT11 Sensor** – measures temperature and humidity.
- **MQ9 Sensor** – detects gas concentration for safety monitoring.
- **PIR Sensor** – senses motion for automation and security.
- **Voltage Sensor** – monitors battery voltage to ensure optimal energy usage.

The ESP32 processes sensor data and communicates via Wi-Fi with the Blynk Cloud, enabling real-time data visualization and remote control through the Blynk mobile application. The relay module connected to the ESP32 controls appliances such as a bulb and fan, allowing users to manage them remotely.

This architecture ensures energy efficiency, cost-effectiveness, and scalability, making it suitable for smart homes, agricultural monitoring, and industrial automation.

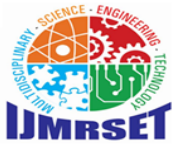

International Journal of Multidisciplinary Research in Science, Engineering and Technology (IJMRSET)

(A Monthly, Peer Reviewed, Refereed, Scholarly Indexed, Open Access Journal)

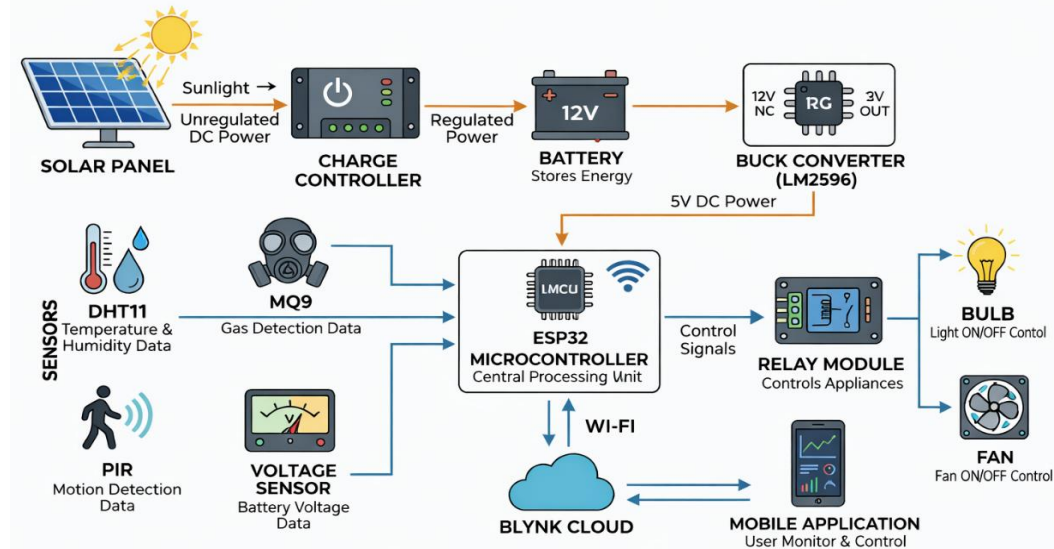

Fig.3.1. Proposed architecture of the solar-powered IoT-based smart monitoring and control system.

IV. METHODOLOGY

The methodology outlines the systematic design and implementation of the proposed solar-powered IoT-based smart monitoring and control system. It involves four major stages: **power generation and regulation**, **data acquisition**, **processing and communication**, and **actuation and control**.

1. Power Generation and Regulation

- A **25W solar panel** converts sunlight into DC electricity.
- The output is fed into an **LS-3000 charge controller**, which regulates voltage and current to protect the **12V, 9Ah battery** from overcharging or deep discharge.
- The battery output is passed through a **buck converter (LM2596)** to step down the voltage from 12V to 5V DC, supplying stable power to the ESP32 microcontroller and sensors.
- This ensures uninterrupted operation even during low sunlight conditions.

2. Data Acquisition

- The **ESP32 microcontroller** collects data from multiple sensors:
 - **DHT11** – Temperature and humidity measurement.
 - **MQ9** – Gas concentration detection.
 - **PIR** – Motion sensing for automation and security.
 - **Voltage Sensor** – Battery voltage monitoring.
- Each sensor is interfaced through GPIO pins, with proper voltage levels and grounding to ensure accurate readings.

3. Processing and Communication

- The ESP32 processes sensor data and transmits it via **Wi-Fi** to the **Blynk Cloud**.
- The **Blynk mobile application** provides a user interface for real-time monitoring and control.
- Data visualization and control commands are exchanged through secure MQTT protocols, ensuring reliable communication between the hardware and cloud.

4. Actuation and Control

- A **4-channel relay module** connected to the ESP32 controls appliances such as a **DC bulb** and **DC fan**.
- The relay operates based on sensor inputs or user commands from the mobile app, enabling automation and remote control.
- The system supports manual override and fault detection through sensor feedback.



International Journal of Multidisciplinary Research in Science, Engineering and Technology (IJMRSET)

(A Monthly, Peer Reviewed, Refereed, Scholarly Indexed, Open Access Journal)

Circuit Diagram

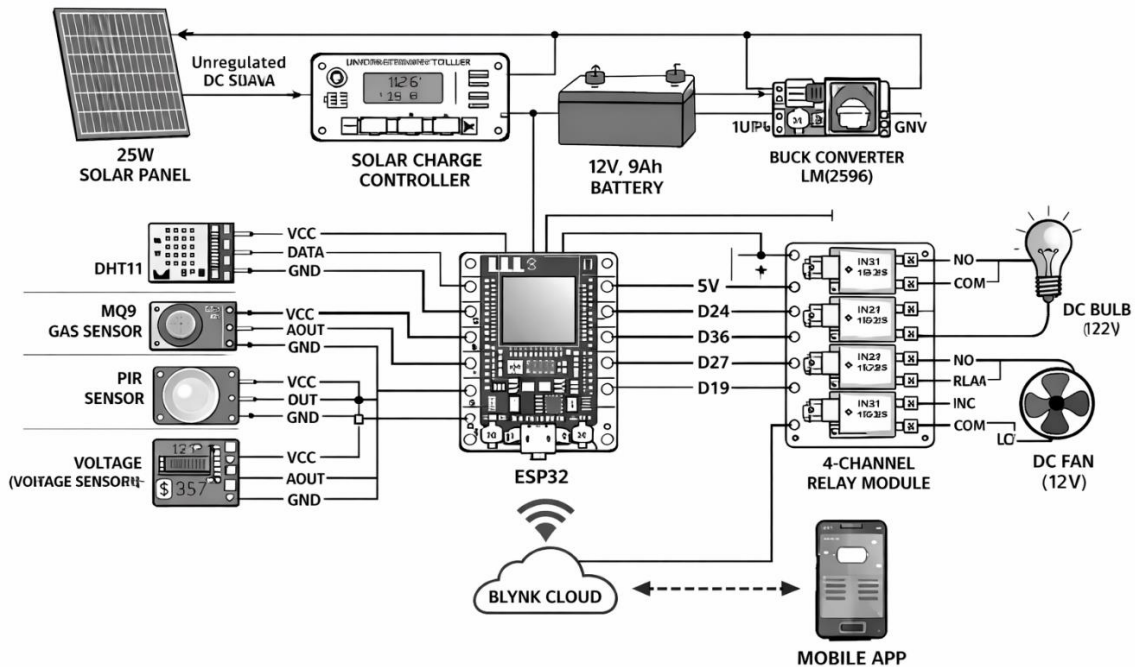

Fig. 4.4.1. Circuit diagram of the solar-powered IoT-based smart monitoring and control system.

V. TOOLS AND PLATFORM

The development of the **solar-powered IoT-based smart monitoring and control system** integrates both hardware and software tools to achieve efficient, reliable, and real-time operation.

Hardware Tools

- **ESP32 Microcontroller:** Central processing unit with built-in Wi-Fi for sensor data acquisition and cloud communication.
- **Multimeter:** Used for measuring voltage, current, and resistance during testing.
- **Breadboard & Sensors (DHT11, MQ9, PIR, Voltage):** Used for prototyping and environmental data collection.



Software Tools

- **Arduino IDE:** Provides a coding and debugging environment for writing and uploading firmware to the ESP32.
- **Blynk Cloud Platform:** Enables real-time monitoring and remote control through a mobile application interface.



International Journal of Multidisciplinary Research in Science, Engineering and Technology (IJMRSET)

(A Monthly, Peer Reviewed, Refereed, Scholarly Indexed, Open Access Journal)

VI. RESULT AND DISCUSSION

A. System Performance Overview

The proposed solar-powered IoT-based smart monitoring and control system was successfully designed, implemented, and tested under real-time operating conditions. The system effectively monitored environmental parameters, managed energy utilization, and enabled remote appliance control through IoT integration. The ESP32 microcontroller continuously collected data from sensors—temperature, humidity, gas concentration, motion, and battery voltage—and transmitted it via Wi-Fi to the Blynk cloud platform for visualization and control.

B. System Output Results

The system performed all intended operations efficiently. The **Blynk dashboard** displayed real-time sensor readings and provided control buttons for appliances such as a bulb and a fan. Environmental variations were accurately reflected on the dashboard, confirming the responsiveness of the sensors and the reliability of the ESP32 data processing. The MQ9 sensor detected gas concentration changes promptly, while the PIR sensor provided precise motion detection signals.

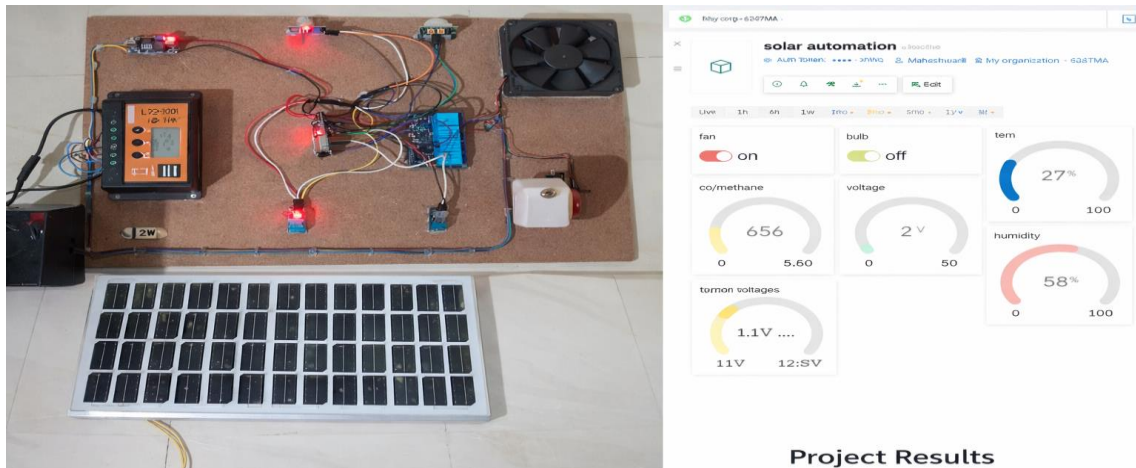

Project Results

Fig. 5.1 shows the real-time monitoring interface of the system, where all sensor values and appliance control states are visualized through the mobile application.

C. IoT Monitoring Results

The IoT monitoring functionality was validated through continuous data transmission between the ESP32 and the Blynk cloud. The system maintained stable Wi-Fi connectivity and ensured uninterrupted data updates. Table V-1 presents the typical range of monitored parameters during testing.

Parameter	Value Range	Relay Response	Status
Temperature	28°C – 32°C	Activated	Normal
Humidity	60% – 75%	Deactivated	Moderate
Gas Level	200 – 350 ppm	Safe	Working
Motion	Detected / Not Detected	Active / Inactive	Working
Battery Voltage	11V – 12.5V	Stable	Working

Table V-1. IoT Monitoring Data

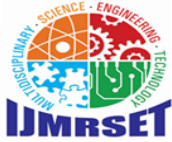

International Journal of Multidisciplinary Research in Science, Engineering and Technology (IJMRSET)

(A Monthly, Peer Reviewed, Refereed, Scholarly Indexed, Open Access Journal)

The results confirm that the system provides accurate and timely updates of environmental conditions. The data visualization on the Blynk dashboard allows users to make informed decisions regarding system operation and energy management.

D. Relay Control Results

Relay control testing verified the system's ability to switch appliances remotely through the IoT platform. The ESP32 received user commands from the Blynk application and activated or deactivated the relay module accordingly. Table V-2 summarizes the relay performance during testing.

Appliance	Command Given	Relay Response	Status
Bulb	ON	Activated	Working
Bulb	OFF	Deactivated	Working
Fan	ON	Activated	Working
Fan	OFF	Deactivated	Working

Table V-2. Relay Control Performance

The relay module responded instantly to all user commands, with no noticeable delay or malfunction. The switching operation was smooth and reliable, confirming the system's suitability for real-time automation.

VII. CONCLUSION AND FUTURE SCOPE

A. Conclusion

The Smart Freelancer Marketplace Application successfully demonstrates an efficient and user-friendly platform for the proposed solar-powered IoT-based smart monitoring and control system successfully integrates renewable energy with intelligent automation. The system efficiently monitors environmental parameters such as temperature, humidity, gas concentration, motion, and battery voltage using the ESP32 microcontroller and transmits real-time data to the Blynk IoT platform via Wi-Fi. Experimental results confirm that the system operates reliably under varying environmental conditions, providing accurate sensor readings and responsive control of appliances such as a bulb and a fan. The integration of solar energy ensures sustainable operation, while IoT connectivity enables remote monitoring and control, making the system suitable for smart homes, agricultural monitoring, and industrial automation.

Overall, the system demonstrates energy efficiency, cost-effectiveness, and scalability, offering a practical solution for modern smart environments powered by renewable energy.

B. Future Scope

The system can be further enhanced through technological advancements and design optimization. Future improvements may include:

- **High-precision sensors** for improved accuracy and reliability.
- **Artificial Intelligence (AI)** integration for predictive control and automated decision-making.
- **Additional sensors** such as soil moisture, light intensity, and air quality for broader environmental monitoring.
- **Mobile alerts and notifications** for critical events like gas leakage or low battery.
- **Upgraded solar panels and battery systems** for higher efficiency and longer operational life.
- **Scalable deployment** for large-scale industrial, agricultural, and smart city applications.

These enhancements will make the system more intelligent, adaptive, and sustainable, contributing to the advancement of **IoT-based renewable energy solutions** for future smart infrastructures.



International Journal of Multidisciplinary Research in Science, Engineering and Technology (IJMRSET)

(A Monthly, Peer Reviewed, Refereed, Scholarly Indexed, Open Access Journal)

REFERENCES

- [1] M. Poyyamozi, B. Murugesan, N. Rajamanickam, M. Shorfuzzaman, and Y. Aboelmagd, "IoT—A promising solution to energy management in smart buildings: A systematic review, applications, barriers, and future scope," *Buildings*, vol. 14, no. 11, p. 3446, 2024. [Online]. Available: <https://doi.org/10.3390/buildings14113446>
- [2] L. Jia, Z. Li, and Z. Hu, "Applications of the Internet of Things in renewable power systems: A survey," *Energies*, vol. 17, no. 16, p. 4160, 2024. [Online]. Available: <https://doi.org/10.3390/en17164160>
- [3] C. K. Rao, S. K. Sahoo, and F. Yanine, "An IoT-based intelligent smart energy monitoring system for solar PV power generation," *Energy Harvesting and Systems*, vol. 11, no. 1, p. 20230015, 2024. [Online]. Available: <https://doi.org/10.1515/ehs-2023-0015>
- [4] C. K. Rao, S. K. Sahoo, and F. Yanine, "A literature review on IoT-based intelligent smart energy management systems for PV power generation," *Hybrid Advances*, vol. 5, p. 100136, 2024. [Online]. Available: <https://doi.org/10.1016/j.hybadv.2023.100136>
- [5] S. B. S. Thanikanti *et al.*, "Energy performance of self-powered green IoT nodes," *Frontiers in Energy Research*, vol. 12, p. 1399371, 2024. [Online]. Available: <https://doi.org/10.3389/fenrg.2024.1399371>
- [6] P. K. Pillai, D. Devaraj, and S. Selvam, "Smart diagnostics of AI-powered IoT solutions for solar grid reliability," *Discover Electronics*, vol. 2, p. 72, 2025. [Online]. Available: <https://doi.org/10.1007/s44291-025-00113-7>
- [7] M. Aarif, P. Anand, L. Das, and A. Anjum, "The impact of smart homes on energy efficiency and sustainability," in *Proc. IEEE UPCON 2023*, 2024. [Online]. Available: <https://doi.org/10.1109/UPCON59197.2023.10434418>
- [8] D. Balamurali, S. Chakankar, G. Sharma, M. Natarajan, and M. Arıcı, "A solar-powered IoT-controlled system: A review," *Environment, Development and Sustainability*, 2025. [Online]. Available: <https://doi.org/10.1007/s10668-024-05953-z>
- [9] "Artificial intelligence, IoT, and solar PV-integrated home energy management systems: A review," *Results in Engineering*, 2025. [Online]. Available: <https://doi.org/10.1016/j.rineng.2025.108954>
- [10] V. Bhardwaj, A. Anooja, L. S. Vermani *et al.*, "Smart cities and the IoT: An in-depth analysis of global research trends and future directions," *Discover Internet of Things*, vol. 4, p. 19, 2024. [Online]. Available : <https://doi.org/10.1007/s43926-024-00076-3>
- [11] S. Safeer, G. D. Mastro, and C. Pulvento, "IoT-based climate-smart systems: A bibliometric analysis," *Frontiers in Sustainable Food Systems*, vol. 8, p. 1406871, 2024. [Online]. Available: <https://doi.org/10.3389/fsufs.2024.1406871>
- [12] M. Nakıp, O. Çopur, E. Biyik, and C. Güzeliş, "Renewable energy management in smart home environments using neural networks," *arXiv preprint*, 2023.
- [13] T. Domínguez-Bolaño, V. Barral, C. J. Escudero, and J. A. García-Naya, "IoT system for smart environments: Challenges and solutions," *arXiv preprint*, 2024.
- [14] M. Nikpour, P. B. Yousefi, H. Jafarzadeh *et al.*, "Intelligent energy management with IoT frameworks in smart cities," *arXiv preprint*, 2023.
- [15] A. Al-Fuqaha, M. Guizani, M. Mohammadi, M. Aledhari, and M. Ayyash, "Internet of Things: A survey on enabling technologies," *IEEE Communications Surveys & Tutorials*, 2015.
- [16] D. Patel and M. Shah, "Solar-powered IoT-based home automation and monitoring system," *J. Renewable Energy Systems*, 2024.
- [17] A. Verma and S. Gupta, "Smart home automation using IoT and cloud computing: A review," *J. Ambient Intelligence and Smart Environments*, 2023.



INTERNATIONAL
STANDARD
SERIAL
NUMBER
INDIA



INTERNATIONAL JOURNAL OF MULTIDISCIPLINARY RESEARCH IN SCIENCE, ENGINEERING AND TECHNOLOGY

| Mobile No: +91-6381907438 | Whatsapp: +91-6381907438 | ijmrset@gmail.com |

www.ijmrset.com